

Hand Gesture Based Recognition And Voice Conversion System For Physically Disabled People

V.Swaminathan, B.Sakthivel, Rohan.K Vishwanath

Student (ECE Department), K.Ramakrishnan College of Technology, Tiruchirappalli.

Mrs.Revathi

Assistant Professor(ECE Department),K.Ramakrishnan College Of Technology,Tiruchirappalli.

Abstract: In this project, a communication system is used based on signal languages, used by dumb people. A narrative hand gesture recognition technique is the basis of this paper. This consists of a hardware module and software algorithm. This project aims to lower the communication gap between the mute community and additionally the standard world. The projected methodology interprets language into speech. The system overcomes the necessary time difficulties of dumb people and improves their manner. Compared with existing system the projected arrangement is compact and is possible to carry to any places.

Keywords: Flex Sensor, Microcontroller, Apr 9600, Relay, Iot Modem

I. Introduction:

Human-computer interaction (HCI) technology is of great importance for the development of intelligent equipment, such as mobile phone, intelligent robot, smart home, and is on the top list of the key research topics and development priorities in the world [1-3]. How to realize the realistic and natural HCI is one of the main research objectives. Due to its natural and intuitive HCI characteristics, vision-based gesture recognition has been widely investigated recently. Although many achievements have been made in gesture recognition, there are still many unresolved challenges, such as the influence of the scale, shape and angle changes of the gestures [4]. It has been shown that gestures with different scales, angles and positions will decrease the recognition rates [5, 6]. Therefore, it is necessary to study the gesture recognition methods to improve the recognition rate of multi-angle multi-scale gestures. In order to increase the hand gesture recognition rate in multi-angle and multi-scale, an enhanced fusion feature HOG-LBP that combines cell structured HOG with 9 uniform patterns LBP is proposed in this paper. The feature has both edge gradient information and texture feature information, as well as the ideal rotation

II. Related Works:

Gesture interaction is widely used as one of the natural and humanized HCI methods, vision-based gesture recognition technology is also a research hotspot. The general process of vision-based gesture recognition includes image preprocessing, feature extraction and classification. One of the challenges in gesture recognition is how to extract the most distinguishing features from the multi-scale and multi-angle gesture pictures, and how to select an appropriate classifier. The widely used 2D features include Hu [7], Gabor [8], Krawtchouk [9], HOG, [10], HOG-HOF [11], and geometric features [12], which generally performance good. Ding et al. [13] extracted the features of Gaussian blurred images and salt and pepper noised pictures by using the cascade method of HOG and LBP, and used the adaboost classifier to classify different gesture images. Gao et al. [14] used adaptive HOG-LBP features to track palms in color images. Cucliciu et al. [15] applied HOG-LBP and adaboost to the analysis of CT/PET images. It can be seen that HOG-LBP is an excellent feature description. However, existing HOG-LBP features are not very effective for multi-scale and multi-angle object recognition. Especially when the scale and angle of the gesture changes, the recognition rate of the above method will decrease significantly. At present, many scholars have done a lot of research on multi-scale and multi-angle gesture recognition. Kopf [16] and Zhang [17] used curvature scale space (CSS) to capture the local features of gestures. But due to the highly flexible human hands, the position of the largest peak in the CSS image was unstable for the same gesture. Liang [18] proposed gesture recognition using radiant projection transform and Fourier transform. The method was normalized for rotation, scaling and translation changes. However, it cannot apply to the gesture recognition where the contours of the border are almost the same. Kelly et al. [19] used the feature of the size function and the Hu moment to represent gestures, where the binary contours was represented by Hu moments and the size function came from the boundary contours. The Hu moment and the size function were combined to realize gesture recognition.

It can be seen from the existing literature that the contour information and texture information are generally used for the gesture recognition. Indirect methods have also achieved some results on multi-scale and

multi-angle gesture recognition. However, the indirect method is easily affected by rotation and modeling accuracy, which will increase uncertainty of the system. Moreover, it will increase the computation burden and time cost and will inevitably reduce the execution efficiency of the system. Therefore, it is necessary to investigate a direct method for the feature based on the scale and angle invariance. This paper proposes an enhanced fusion feature HOG-LBP that combines cell-structured HOG with 9 uniform patterns LBP. The cell-structured HOG can describe complex gesture contour well. The 9 uniform patterns LBP is used to extract texture information for complex gestures and has good rotation invariance. The new feature has rich gesture features including contour features and texture features, as well as good geometric invariance and rotation invariance. Experiment results show that compared with other gesture recognition methods, the proposed algorithm can achieve the highest recognition rate on the home-made data set, the NUS data set and the MUGD data set.

The Proposed Method

In this section the proposed system is presented, which supports the two way communication between disabled and normal person. System consists of two modules i.e. flex sensor to convert gestures to speech and control the appliances. Vision-based gesture recognition is one of the most widely used HCI. But the sensitivity of the recognition algorithm to the size, shape and angle of gestures is one of the unsolved challenges [4]-[6]. The multi-scale multi-angle gesture recognition scheme proposed in this paper includes image pretreatment, feature extraction and classification.

A. Image Pretreatment

Pixels of skin color in YCbCr color space satisfies Gaussian distribution. Experiments show that using the single Gaussian model (SGM) to segment the gesture image is effective and its computational complexity is small, as shown in Fig. 1(a). However, it is very difficult for SGM to eliminate the interference with skin-like backgrounds, as shown in Fig. 1(b). In order to solve the problem, this paper proposes a method of SGM Kmeans gesture segmentation. There are three kinds of pixels in the SGM segmented image: the skin color, the skin-like color and the black background. The K-means algorithm is used to cluster the three pixels. Choosing K as 3, the skin color, skin-like color, and background can be effectively separated from the segmented image, which is shown in Fig. 1(c). It can be seen that our proposed SGM-Kmeans algorithm can effectively eliminate the interference of the skin-like background and obtain a complete gesture image.

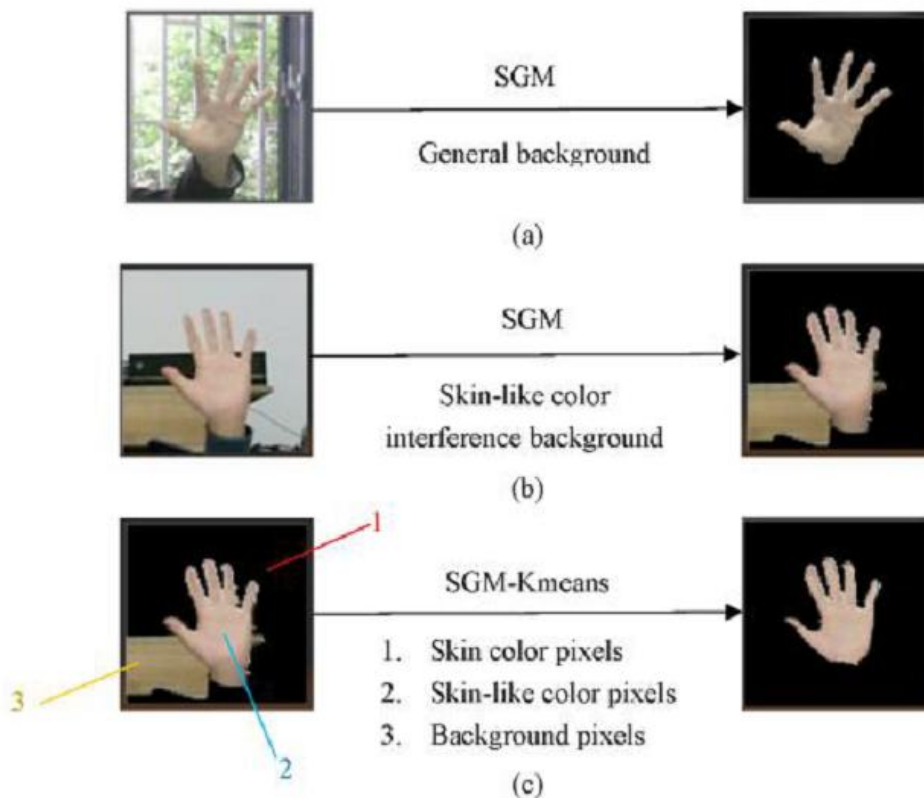

Figure 1. (a) the SGM segmented image in general background. (b) the SGM segmented image in skin-like background. (c) the SGM-Kmeans segmented image in skin-like background.

B. Feature Extraction

Directional gradient histogram (HOG) has achieved great success in target recognition and object detection [22]. As one of the best features for extracting edge and contour information, HOG has good geometric invariance and optical invariance. It can effectively describe the edge and contour features of the target.

In order to reduce the computation for extracting the HOG descriptor, in this paper, the gesture image is resized to 64×64, the HOG feature extraction process is shown in Fig. 2. The calculating steps are indicated as follows:

□ □ First, the color image is reduced to a gray level image. The horizontal gradient and the vertical gradient can be formulated as

Calculate the HOG descriptor of the entire image and connect the descriptors of all cells in the block in order, that is, the feature descriptor (8×8×9=576) of the gesture image.

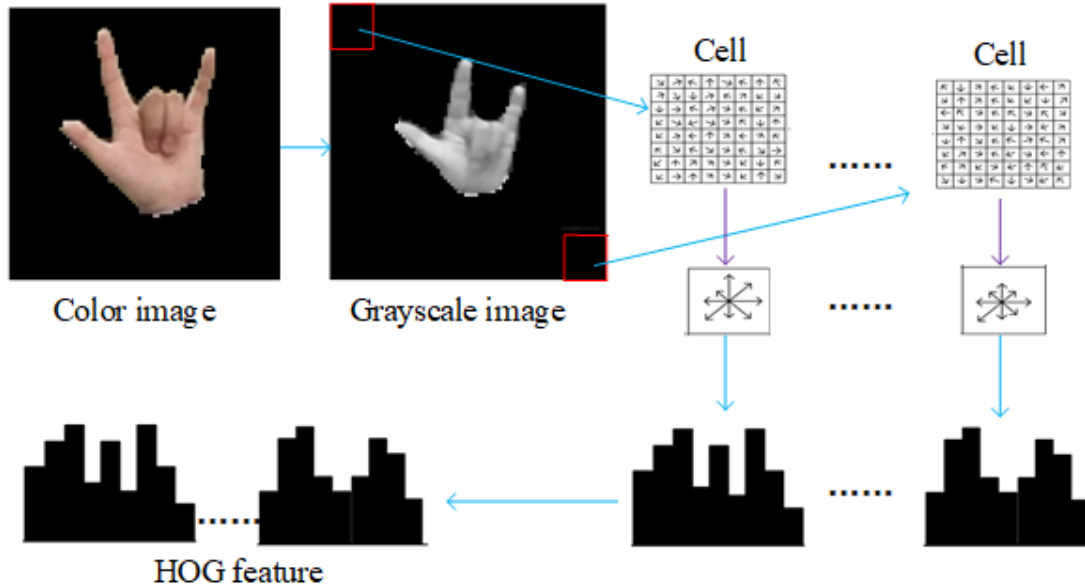
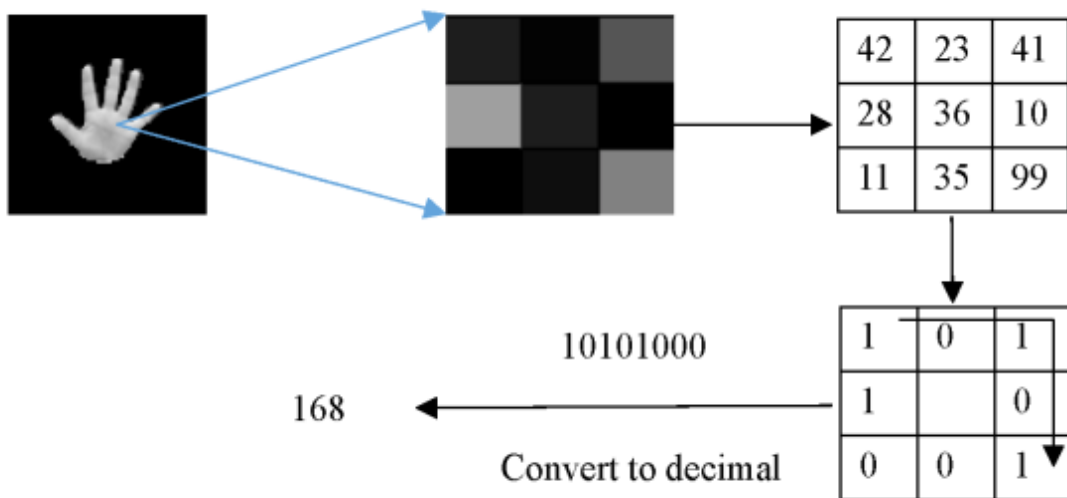

Figure 2. The HOG feature extraction process

Local Binary Pattern (LBP) is often used as an operator to describe the local texture features of an image, which has rotational invariance and gray invariance. With the continuous development and improvement of LBP, it has been widely used in the field of texture segmentation [23]-[25].

The calculation process of the basic LBP descriptor is shown in Fig. 3. The gray value of each pixel is used as a Threshold in the image and then compared with the gray value of the pixel in the 3×3 neighborhood. If the gray value in the neighborhood is greater than the threshold, set the point to 1, otherwise set it to 0. Then, calculate these values in a clockwise direction to obtain the LBP encoded value of the window.



Block Diagram:

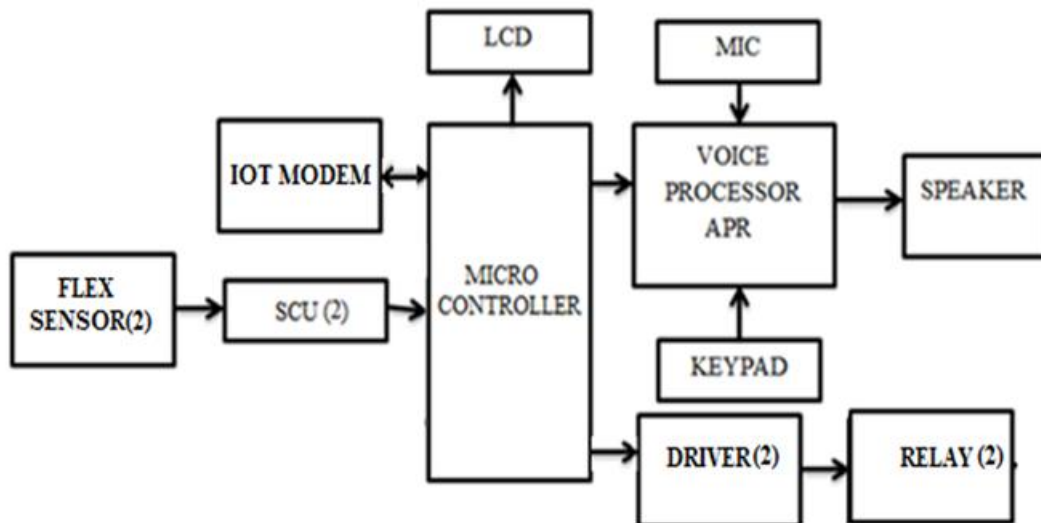

LCD: LCD (liquid crystal display) is the technology used for displays in notebook and other smaller computers. Like light-emitting diode (LED) and gas-plasma technologies, LCDs allow displays to be much thinner than cathode ray tube (CRT) technology.

MIC: A **microphone** is a transducer that converts sound into an electrical signal.

SPEAKER:Speakers are transducers that convert electromagnetic waves into sound waves.

KEYPAD:A Keypad is a set of buttons arranged in a block or “pad” which bear digits,symbols or alphabetical letters.

SCU:A Control unit or CU is circuitry that directs operations within a computer’s processor.

RELAY: A **relay** is an electrically operated switch. Relays are used where it is necessary to control a circuit by a separate low-power signal, or where several circuits must be controlled by one signal.

FLUX SENSOR: **flux sensor** is a **transducer** that generates. an electrical signal proportional to the total heat rate applied to the surface of the **sensor**.

DRIVER: A **driver** is a group of files that enable one or more hardware devices to communicate with the **computer's**operating system.

PROJECT FLOW DIAGRAM:

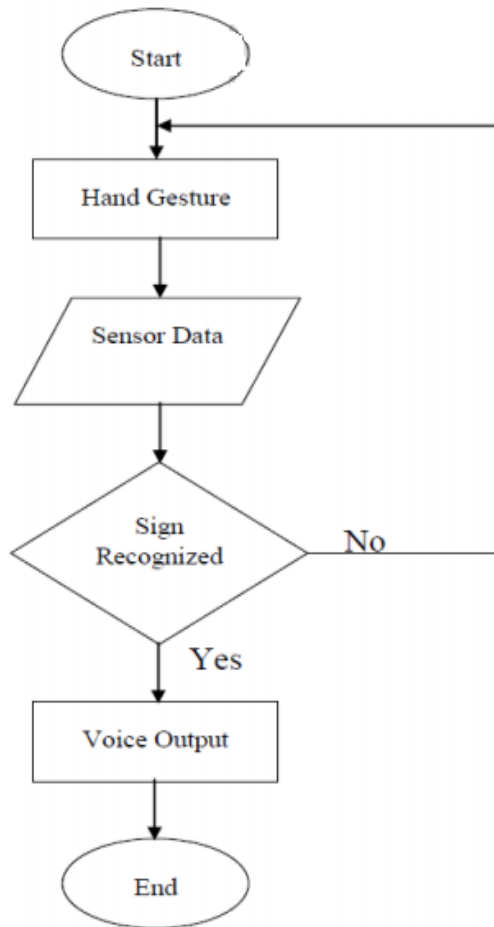

FEATURES ADDITION:

- This project aims to lower the communication gap between the mute community and additionally the standard world. The projected methodology interprets language into speech.
- The system overcomes the necessary time difficulties of dumb people and improves their manner. Compared with existing system the projected arrangement is compact and is possible to carry to any places.

ADVANTAGES AND APPLICATIONS:

- This project aims to lower the barrier of communication between mute and deaf community with the normal world.
- This project will be used by dumb and deaf people as Assistant for themselves.

III. Conclusion:

Thus, this project uses flux sensor which converts normal speech into gesture and will help the duff and dumb patient to understand the normal person's speech. This is the biggest takeaway of this project.

References:

- [1]. Kekre, M., and Vaishali, K. "Speaker identification by using vector quantization," IEEE Transactions on mechatronics, Vol. 15, No. 1, pp. 1034-1620, 2010.
- [2]. Istvan, I., Zoran, M., and Nikola, D. "Handsfree voice communication with TV", IEEE Transactions on consumer electronics, Vol. 17, No. 2, pp. 1378-1695, 2011
- [3]. Amarjot, S., Devinder, K., Phani, S., Srikrishna, K., and Niraj, A. "An intelligent multi-gesture spotting robot to assist persons with disabilities", International journal of computer theory and engineering, Vol. 4, No. 6, pp. 1290-1420, 2012.
- [4]. Joyeeta, S., and Karen, D. "Indian Sign Language Recognition Using Eigen Value Weighted Euclidean Distance Based Classification Technique", International journal of advanced computer science and applications, Vol. 4, No. 2, pp. 434-820, 2013.
- [5]. Interacting Device for Deaf & Dumb using Atmega 328 Processor-International Journal of Engineering and Computer Science
- [6]. C. Zou, Y. Liu, J. Wang, et al, "Deformable part model based hand detection against complex backgrounds," Advances in Image and Graphics Technologies, IGTA 2016 Book Series: Communications in Computer and Information Science, vol 634, pp.149-159, 2016