

Implementation of Wireless Sensor Networks for Industrial Applications Using the Multi-Core Architecture

T Maheshwar¹, B Anveshraj², S Rakesh³
^{1,2,3} Dept Of ECE, SreeDattha Institute of Engineering & Science

Abstract: *Advancements in silicon technology, embedded systems, sensors, micro-electro-mechanical systems, and wireless communications have led to the emergence of embedded wireless sensor networks (EWSNs). EWSNs consist of sensor nodes with embedded sensors to sense data about a phenomenon and these sensor nodes communicate with neighboring sensor nodes over wireless links (we refer to wireless sensor networks (WSNs) as EWSNs since sensor nodes are embedded in the physical environment/system). EWSNs have applications in various domains, including surveillance, environment monitoring, traffic monitoring, volcano monitoring, and health care. In this paper, we consider ARM multicore which acts as hierarchical MCEWSN for information fusion such that controller receives sensing measurements from single-core sensor nodes equipped with temperature, LDR and smoke sensor through wireless network(Zigbee) and also it receives data from the camera. Whatever information the controller receives, it will be displayed on Display unit and through wifi, we can watch the received data on remote pc/laptop by unique IP address provided.*

Keywords: ARM board, EWSN, Zigbee

I. Introduction

Embedded wireless sensor networks (EWSNs) consist of sensor nodes with embedded sensors to sense data about a phenomenon and these sensor nodes communicate with neighboring sensor nodes over wireless links. Many emerging EWSN applications (e.g., surveillance, volcano monitoring) require a plethora of sensors (e.g., acoustic, seismic, temperature, and, more recently, image sensors and/or smart cameras) embedded in the sensor nodes. Although traditional EWSNs equipped with scalar sensors (e.g., temperature, humidity) transmit most of the sensed information to a sink node (base station node), this *sense-transmit* paradigm is becoming infeasible for information-hungry applications equipped with a plethora of sensors, including image sensors and/or smart cameras. Processing and transmission of the large amount of sensed data in emerging applications exceeds the capabilities of traditional EWSNs. For example, consider a military EWSN deployed in a battlefield, which requires various sensors, such as imaging, acoustic, and electromagnetic sensors. This application presents various challenges for existing EWSNs since transmission of high-resolution images and video streams over bandwidth-limited wireless links from sensor nodes to the sink node is infeasible. Furthermore, meaningful processing of multimedia data (acoustic, image, and video in this example) in real-time exceeds the capabilities of traditional EWSNs consisting of single-core embedded sensor nodes [1], [2], and requires more powerful embedded sensor nodes to realize this application.

Since single-core EWSNs will soon be unable to meet the increasing requirements of information-rich applications (e.g., video sensor networks), next generation sensor nodes must possess enhanced computation and communication capabilities. For example, the transmission rate for the first generation Mica motes was 38.4 kbps whereas the second generation Mica motes (MicaZ motes) can communicate at 250 kbps using IEEE 802.15.4 (Zigbee) [3]. Despite these advances in communication, limited wireless bandwidth from sensor nodes to the sink node makes timely transmission of multimedia data to the sink node infeasible. In traditional EWSNs, the communication energy dominates the computation energy. For example, an embedded sensor node produced by Rockwell Automation [4] expends 2000_ more energy for transmitting a bit than that of executing a single instruction [5]. Similarly, transmitting a 15 frames per second (FPS) digital video stream over a wireless Bluetooth link takes 400 mW [6].

Technological advancements in multi-core architectures have made multi-core processors a viable and cost-effective choice for increasing the computational ability of embedded sensor nodes. Multi-core embedded sensor nodes can extract the desired information from the sensed data and communicate only this processed information, which reduces the data transmission volume to the sink node. By replacing a large percentage of communication with in-network computation, multi-core embedded sensor nodes could realize large energy savings that would increase the sensor network's overall lifetime.

II. EWSN (Wireless Sensor Network)

An embedded sensor network is a network of embedded computers placed in the physical world that interacts with the environment. These embedded computers, or sensor nodes, are often physically small, relatively inexpensive computers, each with some set of sensors or actuators. These sensor nodes are deployed in situ, physically placed in the environment near the objects they are sensing. Sensor nodes are networked, allowing them to communicate and cooperate with each other to monitor the environment and (possibly) effect changes to it. Current sensor networks are usually stationary, although sensors may be attached to moving objects or may even be capable of independent movement. These characteristics: being embedded, and being capable of sensing, actuation, and the ability to communicate, define the field of sensor networking and differentiate it from remote sensing, mobile computing with laptop computers, and traditional centralized sensing systems. As of 2004, sensor networking is a very active research area with well-established hardware platforms, a growing body of software, and increasing commercial interest. Sensor networks are seeing broader research and commercial deployments in military, scientific, and commercial applications including monitoring of biological habitats, agriculture, and industrial processes.

III. Proposed System

The Block diagram depicts the architecture of a multi-core embedded sensor node in our MCEWSN. The multi-core embedded sensor node consists of a sensing unit, a processing unit, a storage unit, a communication unit, a power unit, an optional actuator unit, and an optional location finding unit.

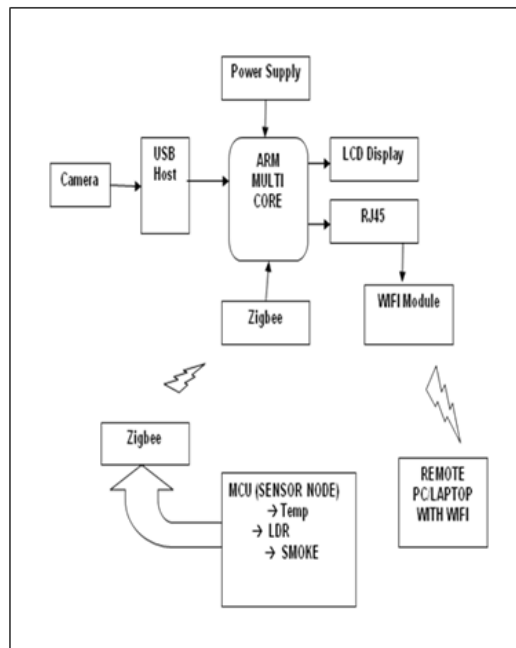

Fig.1: Proposed System

IV. Hardware Implementation

A. RASPBERRY PI BOARD

The **Raspberry Pi** is a credit-card-sized single-board computer developed in the UK by the Raspberry Pi Foundation with the intention of promoting the teaching of basic computer science in schools.



The Raspberry Pi is manufactured in two board configurations through licensed manufacturing deals with Newark element14 (Premier Farnell), RS Components and Egoman. These companies sell the Raspberry Pi online. Egoman produces a version for distribution solely in China and Taiwan, which can be distinguished from

other Pis by their red coloring and lack of FCC/CE marks. The hardware is the same across all manufacturers. The Raspberry Pi has a Broadcom BCM2835 system on a chip (SoC), which includes an ARM1176JZF-S 700 MHz processor, Video Core IV GPU, and was originally shipped with 256 megabytes of RAM, later upgraded to 512 MB. It does not include a built-in hard disk or solid-state drive, but uses an SD card for booting and persistent storage.

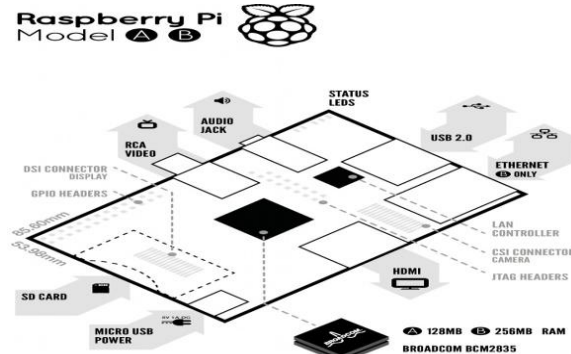

Fig2. Board features

The Foundation provides Debian and Arch Linux ARM distributions for download. Tools are available for Python as the main programming language, with support for BBC BASIC (via the RISC OS image or the Brandy Basic clone for Linux), C, Java and Perl.

B. UVC driver Camera

A UVC (or Universal Video Class) driver is a USB-category driver. A driver enables a device, such as your webcam, to communicate with your computer's operating system. And USB (or Universal Serial Bus) is a common type of connection that allows for high-speed data transfer. Devices that are equipped with a UVC driver, such as the Logitech® QuickCam® Pro 9000 for Business, are capable of streaming video. In other words, with a UVC driver, you can simply plug your webcam into your computer and it'll be ready to use.



Fig.3:UVC driver camera

C. Ethernet LAN:

Ethernet is a family of computer networking technologies for local area networks (LANs). Ethernet was commercially introduced in 1980 and standardized in 1983 as IEEE 802.3. Ethernet has largely replaced competing wired LAN technologies such as token ring, FDDI, and ARCNET. The Ethernet standards comprise several wiring and signaling variants of the OSI physical layer in use with Ethernet. Data rates were periodically increased from the original 10 megabits per second to 100 gigabits per second.

D. Temperature Sensor:

LM35 is a precision IC temperature sensor with its output proportional to the temperature (in °C). With LM35, temperature can be measured more accurately than with a thermistor.



Fig.4: Temperature Sensor

E. LDR Sensor:

LDRs or Light Dependent Resistors are very useful especially in light/dark sensor circuits. Normally the resistance of an LDR is very high, sometimes as high as 1000 000 ohms, but when they are illuminated with light resistance drops dramatically.

F. ZIGBEE:

Zigbee is a low power spin off of WiFi. It is a specification for small, low power radios based on IEEE 802.15.4 – 2003 Wireless Personal Area Networks standard. The specification was accepted and ratified by the Zigbee alliance in December 2004.



Fig.6: Zigbee module

Zigbee Alliance is a group of more than 300 companies including industry majors like Philips, Mitsubishi Electric, Epson, Atmel, Texas Instruments etc.

V. Software Requirements

A. Linux Operating System:

Linux or GNU/Linux is a free and open source software operating system for computers. The operating system is a collection of the basic instructions that tell the electronic parts of the computer what to do and how to work. Free and open source software (FOSS) means that everyone has the freedom to use it, see how it works, and changes it. There is a lot of software for Linux, and since Linux is free software it means that none of the software will put any license restrictions on users. This is one of the reasons why many people like to use Linux.

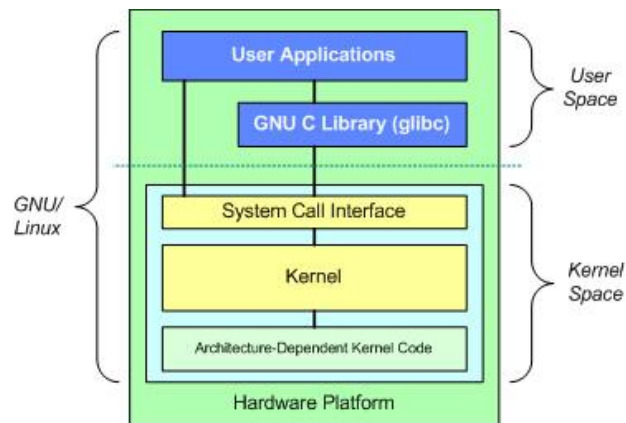

Fig7. Architecture of Linux Operating System

A Linux-based system is a modular Unix-like operating system. It derives much of its basic design from principles established in UNIX during the 1970s and 1980s. Such a system uses a monolithic kernel, the Linux kernel, which handles process control, networking, and peripheral and file system access. Device drivers are either integrated directly with the kernel or added as modules loaded while the system is running.

B. Qt for Embedded linux:

Qt is a cross-platform application framework that is widely used for developing application software with a graphical user interface (GUI) (in which cases Qt is classified as a widget toolkit), and also used for developing non-GUI programs such as command-line tools and consoles for servers. Qt uses standard C++ but makes extensive use of a special code generator (called the Meta Object Compiler, or moc) together with several macros to enrich the language. Qt can also be used in several other programming languages via language bindings. It runs on the major desktop platforms and some of the mobile platforms. Non-GUI features include SQL database access, XML parsing, thread management, network support, and a unified cross-platform application programming interface for file handling. It has extensive internationalization support.

VI. Results



VII. Conclusion

The project “**Multi-Core Embedded Wireless Sensor Networks: Architecture and Applications**” has been successfully designed and tested. It has been developed by integrating features of all the hardware components and software used. Presence of every module has been reasoned out and placed carefully thus contributing to the best working of the unit. Secondly, using highly advanced ARM board and with the help of growing technology the project has been successfully implemented.

References

- [1]. I.F. Akyildiz, T. Melodia, and K.R. Chowdhury, “Wireless Multimedia Sensor Networks: Applications and Testbeds,” Proc. IEEE, vol. 96, no. 10, pp. 1588-1605, Oct. 2008.
- [2]. I.F. Akyildiz, W. Su, Y. Sankarasubramaniam, and E. Cayirci, “Wireless Sensor Networks: A Survey,” Elsevier Comput. Netw., vol. 38, no. 4, pp. 393-422, Mar. 2002.
- [3]. Y. Liu and S.K. Das, “Information-Intensive Wireless Sensor Networks: Potential and Challenges,” IEEE Commun. Mag., vol. 44, no. 11, pp. 142-147, Nov. 2006.
- [4]. Rockwell Automation, Oct. 2011. [Online]. Available: www.rockwellautomation.com
- [5]. T.T.-O. Kwok and Y.-K. Kwok, “Computation and Energy Efficient Image Processing in Wireless Sensor Networks Based on Reconfigurable Computing,” in Proc. ICPPW, Columbus, OH, USA, Aug. 2006, pp. 43-50.
- [6]. R. Kleihorst, B. Schueler, A. Danilin, and M. Heijligers, “Smart Camera Mote with High Performance Vision System,” in Proc. Workshop DSC, Boulder, CO, USA, Oct. 2006, pp. 1-5.
- [7]. A. Munir, A. Gordon-Ross, and S. Ranka, “Parallelized Benchmark-Driven Performance Evaluation of SMPs and Tiled Multi-Core Architectures for Embedded Systems,” in Proc. IEEE IPCCC, Austin, TX, USA, Dec. 2012, pp. 416-423.
- [8]. “Tilera Multicore Development Environment: ILib API Reference Manual” Tilera Official Documentation, TILERA, Apr. 2008. MUNIR ET AL.: MULTI-CORE EMBEDDED WIRELESS SENSOR NETWORKS 1561
- [9]. A.Y. Dogan, D. Atienza, A. Burg, I. Loi, and L. Benini, “Power/Performance Exploration of Single-Core and Multi-Core Processor Approaches for Biomedical Signal Processing,” in Proc. Workshop PATMOS, Madrid, Spain, Sept. 2011, pp. 102-111.
- [10]. M. Coates, “Distributed Particle Filters for Sensor Networks,” in Proc. IEEE/ACM 3rd Int’l Symp. IPSN, Berkeley, CA, USA, Apr. 2004, pp. 99-107.
- [11]. R. Rajagopalan and P. Varshney, “Data-Aggregation Techniques in Sensor Networks: A Survey,” IEEE Commun. Surveys Tuts. vol. 8, no. 4, pp. 48-63, 2006.
- [12]. R. Kulkarni, A. Forster, and G. Venayagamoorthy, “Computational Intelligence in Wireless Sensor Networks: A Survey,” IEEE Commun. Surveys Tuts., vol. 13, no. 1, pp. 68-96, 2011.
- [13]. W. Li, T. Arslan, J. Han, A.T. Erdogan, A. El-Rayis, N. Haridas, and E. Yang, “Energy Efficiency Enhancement in Satellite Based WSN through Collaboratoin and Self-Organized Mobility,” in Proc. IEEE Aerosp. Conf., Big Sky, MT, USA, Mar. 2009, pp. 1-8.