

## High Efficient Asynchronous Buck Converter For Biomedical Devices

<sup>1</sup>M.M.Shanmugapriya, <sup>2</sup>B.Sheryl Nivya,

<sup>1</sup> PG Student, Department of Electrical Engineering

<sup>2</sup> Asst professor, Sri lakshmi Ammal Engineering College, Anna University, Chennai, India,

---

**Abstract:** In this project, we present a fully integrated asynchronous step-down switched capacitor dc-dc conversion structure suitable for supporting ultra-low-power circuits commonly found in biomedical devices. The proposed converter uses a PI controller as the heart of the control circuitry to generate the drive signals. To minimize the switching losses, the controller scales the switching frequency of the drive signals according to the loading conditions. A total of 350 pF on-chip capacitance was implemented to support a maximum of 230-W load power. Experimental test results confirm the expected functionality and performance of the proposed circuit.

**Index Terms :** Asynchronous control, biomedical devices, dc-dc power converters, dynamic voltage scaling, power management, voltage-scalable switched capacitor.

---

### I Introduction

In the recent years, high frequency switching converters applications in the dc power distribution are increasing. Particularly in the area of biomedical systems, the main focus is on medical implants. As the power conversion system is becoming miniaturized, increasing the power density is one of the challenging issues. Nowadays, switching mode converters with higher power density and low electromagnetic interference (EMI) is required. Several types of switch-mode dc-dc converters (SMDC), belongs to buck, boost and buck-boost topologies, have been developed and reported to meet variety of applications. Major concern in medical, automotive and telecom power supply systems, is to meet the increased power demand and to reduce the burden on the primary energy source. Battery life is an important issue in all portable electronic devices. The matter becomes even more crucial when the battery enabled devices are medical implants. In these devices, life itself might become dependent on the battery life. Naturally, as with all battery-powered devices, the battery of an implant must be replaced after a certain period of time. A frequent change of an implant's battery is not desired because it requires surgical procedure. Whether the implant is powered by a battery, inductive link, piezoelectric source, or a combination of these sources, it is important to have circuits with ultra-low-power consumption that would efficiently use these energy resources. Reducing the power dissipation in these circuits also helps to reduce the risk of damaging surrounding tissues due to dissipated heat. We propose a fully asynchronous controller that varies the frequency depending on the topology used and the output current delivered. By doing so, the controller reduces the switching to the minimum necessary and, thus, reduces the switching losses in the converter. Moreover, to operate over a wide range of output voltages with good efficiency, the proposed SC dc-dc converter switches between three different topologies. An important point to remember about all DC-DC converters is that like a transformer, they essentially just change the input energy into a different impedance level. So whatever the output voltage level, the output power all comes from the input; there is no energy manufactured inside the converter. Nowadays some types of converter achieve an efficiency of over 90%, using the latest components and circuit techniques. Most others achieve at least 80-85%. There are many different types of DC-DC converter, each of which tends to be more suitable for some types of application than for others. The non-isolating type of converter is generally used where the voltage needs to be stepped up or down by a relatively small ratio (say less than 4:1), and there is no problem with the output and input having no dielectric isolation. There are five main types of converter in this non-isolating group, usually called the buck, boost, buck-boost, and Cuk and charge-pump converters. The buck converter is used for voltage step-down/reduction, while the boost converter is used for voltage step-up. The buck-boost and Cuk converters can be used for either step-down or step-up, but are essentially voltage polarity reversers or inverters as well. The charge-pump converter is used for either voltage step-up or voltage inversion, but only in relatively low power applications. The perfect DC-DC converter would be one where none of the incoming DC energy is wasted in the converter; it would all end up converted and fed to the output. Inevitably practical converters have losses;

voltage drops due to resistance in the inductor or transformer windings, on resistance in the MOSFETs, forward voltage drop in the rectifier diodes, eddy current and hysteresis losses in the inductor or transformer, and so on. It's the job of the converter designer to reduce all of these losses to the lowest possible level, to make the converter as efficient as possible. MOSFETs used as switches in most of the converter circuits. That's because modern MOSFETs make the most efficient electronic switches of high/low DC currents. When they are off, they are virtually an open circuit, and when they are on, they are very close to a short circuit, typically only a few milliohms. So they waste very little power. However, the power conversion efficiency and its control is major challenge in the power conversion. The steady state efficiency improvement with higher power density of the total conversion system is one of the key parameter that needs to be addressed. The other constraint is to use a simple control strategy. To meet some of these design challenges, multi-input converters with different topology combinations are to be used. In this project, we present a fully integrated asynchronous step-down switched capacitor dc-dc conversion structure suitable for supporting ultra-low-power circuits commonly found in biomedical devices. The proposed converter uses a PI controller as the heart of the control circuitry to generate the drive signals. To minimize the switching losses, the controller scales the switching frequency of the drive signals according to the loading conditions.

## II Proposed System

### 2.1 Block Diagram of Proposed System

The block diagram of proposed system consists switched capacitor dc-dc converter network, DC input, pulse generator, PI controller and Resistive load.

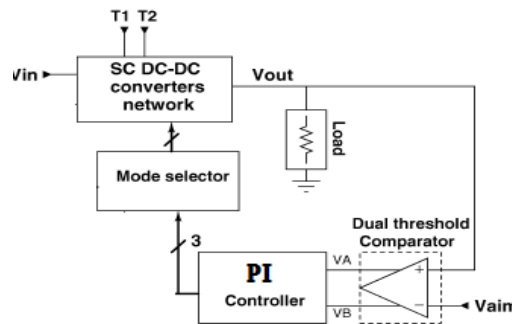

Fig 2.1 Block Diagram of Proposed System

Here, the function of switched capacitor to provide continuous supply to the load through proper selection of capacitor network. DC input is given to the dc-dc converter network. Switched capacitor starts charging based on the selected gate pulse. PI Controller will generate the triggering pulses to activate the converter based on comparing the output voltage with the reference voltage. Thus Output capacitor provides continuous supply to the Resistive load. In practical, biomedical device can be connected in place of resistive load for continuous output.

### 2.2 Circuit Diagram

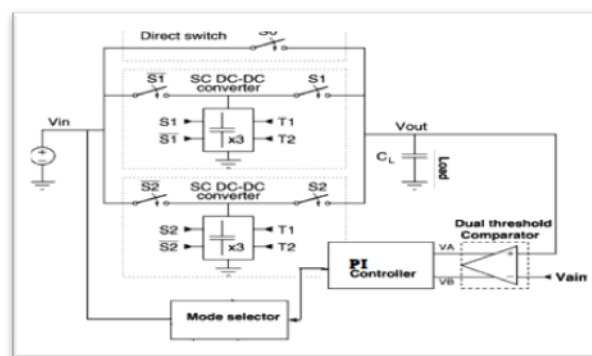

Fig 2.2 Circuit Diagram Of Proposed System

### 2.1 Operation and Principle:

When the circuit first starts, the controller senses that output voltage is less than both thresholds ( $V_{AREF}=0.27\text{mV}$  and  $V_{BREF}=0.1\text{mV}$ ) and sets the drive signals so that the output and the two switched capacitors (SC) converters start to charge. At this stage, the output capacitor is charged directly from the input via the direct switch, which makes the charge up time very short. Once output voltage reaches  $V_{AREF}$ , an overshoot in the output voltage will occur. During that period, the controller will turn OFF the direct switch while keeping the SC converters charging. The load consumes the accumulated charge from the output capacitor, so that the output voltage will decrease below  $V_{AREF}$ . As the output voltage starts to drop below  $V_{AREF}$ , the controller connects the first Switched capacitor (SC1) converters to the load. At normal loading conditions, the charge stored in the SC1 converter will be sufficient to pull the output voltage once again above  $V_{AREF}$ . The connected SC1 converter will supply the output with the needed charges to sustain  $V_{OUT}$  above  $V_{AREF}$  until the load consumes some part of the available charge. When the output voltage drops again below  $V_{AREF}$ , the controller will switch the output to the SC2 converter, while the previous converter SC1 recharges. As the load current increases, the system will reach a point where a fully charged SC2 converter cannot pull up the output voltage above the threshold voltage. This means that the controller cannot detect any change in the output voltage and will keep the current SC2 converter connected to the load. As the charge in the SC2 converter depletes, the output voltage will start to decrease until it reaches  $V_{BREF}$ . This threshold serves as a safety net for output voltage. When the output voltage goes below  $V_{BREF}$ , the controller will reset and activate the direct switch while recharging both SC converters. This will pull back  $V_{OUT}$  to  $V_{AREF}$  and the controller will attempt to support the load again with the SC1 converter.

### 2.3 PI Controller

A proportional–integral (PI controller) is a generic control loop feedback mechanism (controller) widely used in industrial control systems – a PI is the most commonly used feedback controller. A PI controller calculates an "error" value as the difference between a measured process variable and a desired set point. The controller attempts to minimize the error by adjusting the process control inputs.

In the proposed system PI controller compares the output voltage with the reference voltage and set the drive signals to reduce the error value to minimum level

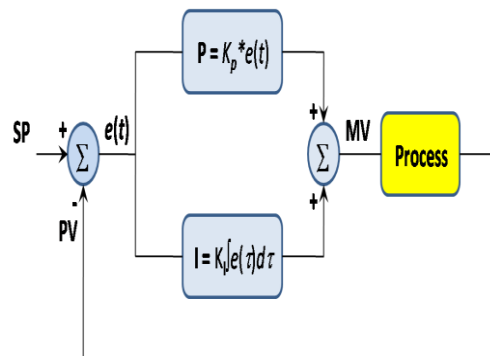

Fig 3.8 PI Controller

The PI controller calculation (algorithm) involves two separate constant parameters, and is accordingly sometimes called two-term control: the proportional, the integral, denoted P,I. Heuristically, these values can be interpreted in terms of time: P depends on the present error, I on the accumulation of past errors. The weighted sum of these two actions is used to adjust the voltage via a control element such as the switching pulses to the converter, or the direct switch. By tuning the two parameters in the PI controller algorithm, the controller can provide control action designed for specific output requirements. The response of the controller can be described in terms of the responsiveness of the controller to an error, the degree to which the controller overshoots the set point and the degree of system oscillation. Some applications may require using only one or two actions to provide the appropriate system control. This is achieved by setting the other parameters to zero. A PID controller will be called a PI, PD, P or I controller in the absence of the respective control actions. PI controllers are fairly common, since derivative action is sensitive to measurement noise, whereas the absence of an integral term may prevent the system from reaching its target value due to the control action.

### **III Batteries Used In Medical Implants**

Batteries used in implantable devices-present unique challenges to their developers and manufacturers in terms of high levels of safety and reliability. In addition, the batteries must have longevity to avoid frequent replacements. Technological advances in leads/electrodes have reduced energy requirements by two orders of magnitude. Microelectronics advances sharply reduce internal current drain concurrently decreasing size and increasing functionality, reliability, and longevity. It is reported that about 600,000 pacemakers are implanted each year worldwide and the total number of people with various types of implanted pacemaker has already crossed 3 million. A cardiac pacemaker uses half of its battery power for cardiac stimulation and the other half for housekeeping tasks such as monitoring and data logging. The first implanted cardiac pacemaker used nickel-cadmium rechargeable battery, later on zinc-mercury battery was developed and used which lasted for over 2 years. Therefore, a 1 amp-hour battery built using lithium iodine technology provides nominally five years of operation in addition to approximately six months of shelf life. Implantable medical devices can be categorized as passive or active devices. Most passive implants are structural devices such as artificial joints, vascular grafts and artificial valves. On the other hand, active implantable devices require power to replace or augment an organ's function or treat associated disease. Some implants that need power to operate and the conditions they are used to treat are listed in

Power to these devices is supplied by one of two means:

1. Internal batteries integrated into the implanted device; or
2. An external power source.

#### **3.1 Power supplies to the implantable devices**

The most important factor for an implantable battery is reliability. Unlike many consumer products, batteries in implantable devices cannot be replaced. They are hard-wired at the time of manufacture, before the device is hermetically sealed. From that point on, the battery is expected to power the device during final testing at the factory, during the shelf life and throughout the useful life of the device while it is implanted. In general, the power source of the implantable device is the only component that has a known and predictable service life, which, in turn, determines the service life of the implantable device itself. Currently, implanted batteries are required to power the implant for five to eight years, with minimal drop in the output voltage and without any undesirable effects such as swelling due to generation. Both surgeons and patients demand that implantable devices, and therefore the integrated batteries, be as small as possible. A cardiac pacemaker takes up about 20ml of space, and an implantable defibrillator takes up three to four times that volume. In either case, about half of the occupied space is consumed by the internal battery. Therefore, the energy density (energy/volume) and specific energy (energy/mass) are important considerations for implantable batteries. Most implantable devices are shaped as variations on circular or elliptical objects to avoid having sharp corners that might penetrate the skin or damage surrounding tissues. Therefore, the batteries in these devices are shaped to conform to the overall device geometry, and often approximate a semicircle with a radius of 3cm and a depth of 8mm. The battery itself is hermetically sealed inside the device where the metal case, usually stainless steel, constitutes one of the electrodes. The other terminal of the battery is available via a metal feed-through on the flat portion of the battery. Different types of implantable devices may have radically different power requirements. Devices with low power consumption and those with infrequent high power usage can utilize batteries internal to the device itself. For example, a cardiac pacemaker uses half of its battery power for cardiac stimulation and the other half for housekeeping tasks such as monitoring and data logging. None of these tasks requires high power. Therefore, a 1 amp-hour battery built using lithium iodine technology provides nominally five years of operation in addition to approximately six months of shelf life. Compared with lead, the same volume of lithium provides eight times as much electricity, at one thirtieth the weight. Implantable defibrillators, on the other hand, are capable of providing electrical shocks six orders of magnitude larger than a pacemaker's pulses, but much less frequently. Since the battery alone cannot produce the shock pulse all at once, energy is drained from the battery for a period of about 20 seconds and stored in an internal capacitor before being delivered to the heart. During the charging period, an implantable defibrillator drains 1–2 amps of current, which can be supplied by lithium silver vanadium oxide batteries. Lithium iodine batteries used in implantable medical devices are of a type with solid electrolytes. The anode (negative electrode of the battery) is formed by lithium while the cathode is a complex formed by iodine and a polymer such as poly-2-vinyl pyridine. The solid electrolyte between these two electrodes – lithium iodide – gives the battery several advantages including:

- no potential for leakage;
- increased reliability; and
- extended shelf life of the battery itself (up to 10 years).

However, the lack of liquid electrolyte reduces the mobility of the ions in the electrolyte, limiting the output current of the battery. Nevertheless, the success of lithium iodine batteries in the implantable medical device industry is evidenced by the fact that more than five million of them have been implanted in pacemakers since 1972. Some devices, such as drug pumps, require more current than lithium iodine batteries can deliver. Drug pumps utilize electromechanical actuators to create high pressure inside a chamber and push the drug from the reservoir to its target, such as the cerebrospinal fluid surrounding the spinal cord. This pumping action is not continuous, but is periodic or is triggered by the patient and requires many milliamps of current when the pump is turned on.

#### IV Simulation And Result

In most of the research and development work, the simulation plays a very important role. Without simulation it is quite impossible to proceed further. It should be noted that in power electronics, computer simulation and a proof of concept hardware prototype in the laboratory are complimentary to each other. However computer simulation must not be considered as a substitute for hardware prototype. The objective of this chapter is to describe simulation of open loop control and PI control of Asynchronous Buck Converter Using Open loop Structure. Simulations were performed by using MATLAB to verify that the proposed circuit can be practically implemented in a biomedical system. It helps to confirm the PWM switching strategy for the seven-level inverter. Then this strategy is implemented in a real time environment i.e. the PI to produce the switching signals for MOSFET switches fig 4.1.2 shows the way the switching signals are generated by using two reference signals and triangular carrier signal. The resulting signals for switches sc1, sc2, direct switch and output are shown in 4.2

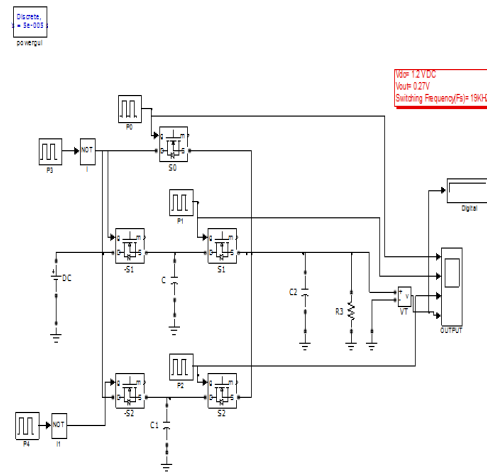

Fig 4.1 Simulink model for open loop control of asynchronous buck converter

Here, a 1.2v input voltage is given to Buck converter. An output of 0.27v is obtained

#### 4.1 Simulation Output for open loop control

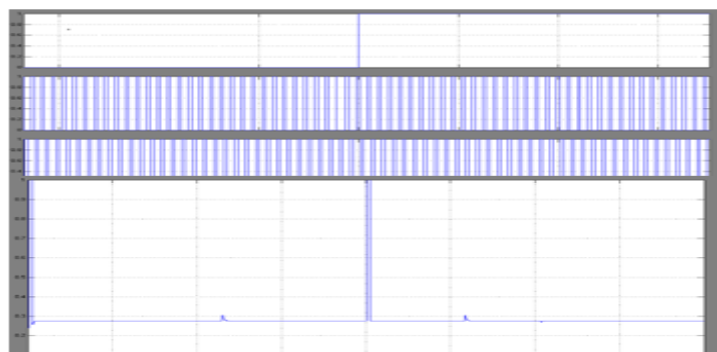

Fig 4.2 Simulation result for open loop control of asynchronous Buck converter

### 4.1.2 Simulation for closed loop control

Here also 1.2V input supply is given to Buck converter. An output of 0.27v is obtained. The pulse for the switch in Buck converter is developed by PI controller. Reference voltage in the PI controller is set as 0.2v. In comparing with the closed loop structure, the control signals are automated using PI controller, thereby error reduces to minimum level and output can be maintained constant throughout.

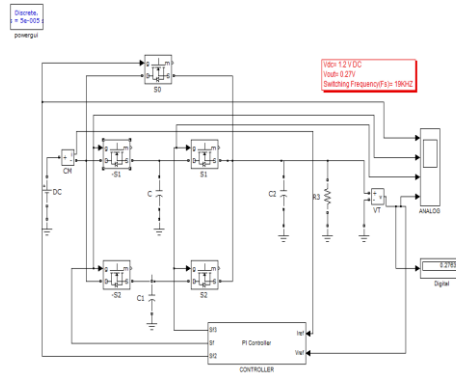

Fig 4.3 Simulink model for closed loop control of asynchronous buck converter

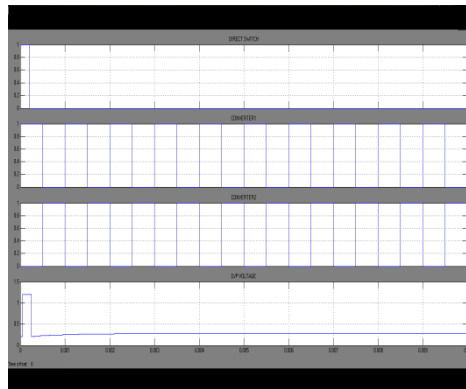

Fig 4.3 Simulation result for closed loop control of Asynchronous Buck converter

### 4.2 Utilized Converter Parameters

Components	Parameter
Input DC source voltage	1.2v
Output Voltage	0.27V
Switching frequency	19KHz
capacitors	C1,C <sub>2</sub> = 150pF, C0= 100pF
Resistor	10KΩ

Table 4.1 Converter Parameter

### V Conclusion

Continuous output is maintained for portable medical device; thereby medical implant battery life is increased. To reduce switching losses at light loads, the proposed dc-dc converter is able to select a number of switches to operate while it keeps additional switches off. Reducing the power dissipation in the circuit helps in reducing the risk of damaging surrounding tissues due to dissipated heat

## REFERENCES

- [1] K. Agarwal and K. Nowka, "Dynamic power management by combination of dual static supply voltages," in Proc. 8th Int. Symp. Quality Electron. Design, Mar. 2007, pp. 85–92.
- [2] O. Al-Terkawi Hasib, M. Sawan, and Y. Savaria, "Fully integrated Ultra-low-power asynchronously driven step-down dc-dc converter," in Proc. IEEE Int. Symp. Circuits Systems, Paris.
- [3] B. Arntzen and D. Maksimovic, "Switched-capacitor DC/DC converters with resonant gate drive," IEEE Trans. Power Electron., vol. 13, no. 5, pp. 892–902, Sep. 1998.
- [4] Y. Choi, N. Chang, and T. Kim, "Dc-dc converter-aware power management for battery-operated embedded systems," in Proc. 42nd Design Autom. Conf., Jun. 2005, pp. 895–900.
- [5] B. Gosselin, V. Simard, and M. Sawan, "An ultra low-power chopper stabilized front-end for multichannel cortical signals recording," in Proc. Canadian Conf. Electr. Computer. Engineering, May 2004, vol. 4, pp. 2259–2262.
- [6] B. Gosselin and M. Sawan, "An ultra low-power CMOS automatic action potential detector," IEEE Trans. Neural Syst. Rehab. Eng., vol. 17, no. 4, pp. 346–353, Aug. 2009.
- [7] J. Kwong, Y. Ramadass, N. Verma, and A. Chandrakasan, "A 65 nm sub-microcontroller with integrated sram and switched capacitor dc-dc converter," IEEE J. Solid-State Circuits, vol. 44, no. 1, pp. 115–126, Jan. 2009.
- [8] G. Patounakis, Y. Li, and K. Shepard, "A fully integrated on-chip DC-DC conversion and power management system," IEEE J. Solid-State Circuits, vol. 39, no. 3, pp. 443–451, Mar. 2004.
- [9] S. Platt, S. Farritor, K. Garvin, and H. Haider, "The use of piezoelectric Ceramics for electric power generation within orthopedic implants," IEEE/ASME Trans. Mechatron., vol. 10, no. 4, pp. 455–461, Aug. 2005.
- [10] L. Nielsen, C. Niessen, J. Sparso, and K. van Berkel, "Low-power operation using self-timed circuits and adaptive scaling of the supply voltage," IEEE Trans. Very Large Scale Integr. Syst., vol. 2, no. 4, pp. 391–397, Dec. 1994.
- [11] Y. Ramadass and A. Chandrakasan, "Voltage scalable switched capacitor dc-dc converter for ultra-low-power on-chip applications," in Proc. IEEE Power Electron. Specialists Conf., Jun. 2007, pp. 2353–2359.
- [12] Y. Ramadass and A. Chandrakasan, "Minimum energy tracking loop with embedded DC-DC converter enabling ultra-low-voltage operation down to 250 mV in 65 nm CMOS," IEEE J. Solid-State Circuits, vol. 43, no. 1, pp. 256–265, Jan. 2008.
- [13] R. Sarpeshkar, W. Wattanapanitch, S. K. Arfin, B. I. Rapoport, S. Mandal, M. W. Baker, M. S. Fee, S. Musallam, and R. A. Andersen, "Low-power circuits for brain-machine interfaces," IEEE Trans. Biomed. Circuits Syst., vol. 2, no. 3, pp. 173–183, Sep. 2008.
- [14] R. Sarpeshkar, C. Salthouse, J.-J. Sit, M. Baker, S. Zhak, and T.-T. Lu, L. Turicchia, and S. Balster, "An ultra-low-power programmable analog bionic ear processor," IEEE Trans. Biomed. Eng., vol. 52, no. 4, pp. 711–727, Apr. 2005.
- [15] G. Simard, M. Sawan, and D. Massicotte, "High-speed OQPSK and efficient power transfer through inductive link for biomedical implants," IEEE Trans. Biomed. Circuits Syst., vol. 4, no. 3, pp. 192–200, Jun. 2010.
- [16] L. Su, D. Ma, and A. P. Brokaw, "Design and analysis of monolithic step-down sc power converter with subthreshold dpwm control for self-powered wireless sensors," IEEE Trans. Circuits Syst. I, Reg. Papers, vol. 57, no. 1, pp. 280–290, Jan. 2010.
- [17] L. Yuan and G. Qu, "Analysis of energy reduction on dynamic voltage scaling-enabled systems," IEEE Trans. Computer-Aided Design Integr. Circuits Syst., vol. 24, no. 12, pp. 1827–1837, Dec. 2005.