

Synthesis of aircraft vertical channel automatic controller by Standard coefficient method

Nguyen Dong Anh, Phung The Anh

Air defence-Air force Academy, Viet Nam

*Corresponding author Email: donganhnguyen9999@gmail.com

ABSTRACT: Automatic flight control systems occupy an important place on modern aircraft. Without such systems, the effective use of aviation, spacecraft and ballistic missiles is impossible. The structural features of the automatic control system (ACS) are evaluated by its control law, which implies the required dependence of the output signals of the actuators on the set of input signals. One of the main tasks that are solved by the autopilot is the stabilization of the pitch angle and automatic control of it. The automatic control of the angular position is carried out by deflecting the rudders when there are discrepancies between the current and required values of the angular parameters of the aircraft position. The current stage of development of control systems is characterized by the widespread introduction of adaptation principles, the use of on-board digital devices for the formation of control and control algorithms, increasing the reliability of means of obtaining and processing information and executing control commands. The beneficial effect of automation on the aircraft control process is manifested in improving the quality of transients of the aircraft returning to the initial mode in angular parameters after involuntary deviation under the influence of external disturbances. This paper presents the synthesis of an automatic controller of an aircraft's vertical channel using the standard coefficient method.

Keywords: standard coefficient method, aircraft's vertical channel

Date of Submission: 05-09-2024

Date of acceptance: 18-09-2024

I. INTRODUCTION

The objectives of the research work are:

- study of the scheme of the automatic pitch angle control system;
- synthesis and analysis of a stabilization system for a given pitch angle with a static and astatic overload internal loop for stabilization of normal overload;
- synthesis and analysis of a stabilization system for a given pitch angle with an astatic overload internal loop for stabilization of a normal overload with a pilot in the loop;

For synthesis and modeling, we accept the initial data: $H = 4 \text{ Km}$; $V_0 = 800 \text{ Km/h}$; $M = 0,81$; $c_1 = 8$; $c_2 = 8,8$; $c_3 = 15,8$; $c_4 = 1,1$; $c_5 = 0,22$; $c_6/g = 0,47$; $c_9 = 0,18$.

II. SCHEMES AIRCRAFT PITCH ANGLE AUTOMATIC CONTROL SYSTEMS

The most "complete" mathematical model of aircraft motion is presented in the form of a system of nonlinear differential equations, describes its spatial motion at angles other than $\vartheta = \pm 1.57 \text{ rad } (\pm 90^\circ)$. This system of equations is based on the kinetic and dynamic Euler equations of motion of the center of mass and rotation of a solid body around its center of mass is presented in the form (1):

$$\begin{cases}
 I_{xx} \dot{\omega}_x - (I_{yy} - I_{zz}) \omega_y \omega_z - I_{xy} (\dot{\omega}_y - \omega_x \omega_z) = M_{Rx}; \\
 I_{yy} \dot{\omega}_y - (I_{zz} - I_{xx}) \omega_x \omega_z - I_{xy} (\dot{\omega}_x - \omega_y \omega_z) = M_{Ry}; \\
 I_{zz} \dot{\omega}_z - (I_{xx} - I_{yy}) \omega_x \omega_y - I_{xy} (\omega_x^2 + \omega_y^2) = M_{Rz} - P y_p \cos \varphi_p; \\
 m(\dot{V}_x + \omega_y V_z - \omega_z V_y) = P \cos \varphi_p - X \cos \alpha + Y \sin \alpha - G \sin \vartheta; \\
 m(\dot{V}_y + \omega_z V_x - \omega_x V_z) = P \sin \varphi_p + X \sin \alpha + Y \cos \alpha - G \cos \vartheta \cos \gamma; \\
 m(\dot{V}_z + \omega_x V_y - \omega_y V_x) = Z + G \cos \vartheta \sin \gamma; \\
 \omega_x = \dot{\psi} \sin \vartheta + \dot{\gamma}; \\
 \omega_y = \dot{\psi} \cos \vartheta \cos \gamma + \dot{\vartheta} \sin \gamma; \\
 \omega_z = \dot{\psi} \cos \vartheta \sin \gamma + \dot{\vartheta} \cos \gamma; \\
 \dot{x}_g = V_x \cos(\hat{x}_g) + V_y \cos(\hat{y}_g) + V_z \cos(\hat{z}_g); \\
 \dot{y}_g = V_x \cos(\hat{y}_g) + V_y \cos(\hat{y}_g) + V_z \cos(\hat{z}_g); \\
 \dot{z}_g = V_x \cos(\hat{z}_g) + V_y \cos(\hat{z}_g) + V_z \cos(\hat{z}_g).
 \end{cases} \quad (1)$$

Expressions for external forces and moments are presented in the form (2):

$$\begin{cases}
 M_{Rx} = f(m_x(\beta, \chi, \delta_{\vartheta}, \delta_H, \omega_x, \omega_y, M), V, H); \\
 M_{Ry} = f(m_y(\beta, \chi, \delta_{\vartheta}, \delta_H, \omega_x, \omega_y, M), V, H); \\
 M_{Rz} = f(m_z(c_y, \phi_p, \delta_B, \delta_{3AK}, \omega_z, \dot{\alpha}, M), V, H); \\
 X = f(c_x(c_y, \chi, M, \delta_{3AK}, \phi_p, \delta_B), V, H); \\
 Y = f(c_y(\alpha, \chi, M, \delta_{3AK}, \phi_p, \delta_B), V, H); \\
 Z = f(c_z(\beta, \delta_H), V, H); \\
 P = f(\delta_{C.F.}, n_{двиг}, V, H).
 \end{cases} \quad (2)$$

The mathematical model of aircraft movement is the basis for the synthesis of autopilot.

In general, a linear non-stationary model of aircraft movement can be represented as (3):

$$\dot{x}(t) = A(t)x(t) + B(t)u(t), \quad t \geq 0. \quad (3)$$

In most cases of aircraft movement, the coefficients of the matrices $A(t)$ and $B(t)$ are smooth functions of time with relatively small rates of change. This allows the use of the "frozen coefficients" method, which leads to a linear stationary model of aircraft movement (horizontal rectilinear flight) ($\vartheta \approx 0, \gamma \approx 0, \beta \approx 0$) is represented as (4):

$$\dot{x}(t) = Ax(t) + Bu(t), \quad t \geq 0. \quad (4)$$

Here, the coefficients of the matrices A and B are similar to the corresponding coefficients of the matrix $A(t)$ and $B(t)$, but are constant for a given aircraft flight mode.

Assuming $V = \text{const.}$ the short-period motion will have the form (5):

$$A_{\text{кп}} = \begin{bmatrix} -c'_1 & -c'_2 & 0 & 0 \\ 1 & -c_4 & 0 & c_{10} \\ 0 & -c_6 & 0 & c_6 \\ 1 & 0 & 0 & 0 \end{bmatrix}; \quad (5)$$

$$x_{\text{кп}}^T(t) = [\omega_z(t) \quad \alpha(t) \quad H(t) \quad \vartheta(t)] ;$$

$$c'_1 = c_1 + c_5;$$

$$c'_2 = c_2 + c_4 c_5;$$

$$B_{\text{кп}}^T = [-c_3 \quad -c_9];$$

$$u_{\text{кп}}(t) = \delta_B;$$

$$c_1 = -\bar{M}_z^{\omega z} = -\frac{1}{J} (\bar{M}_z^{\omega z})_0, 1/c^2;$$

$$c_2 = -\bar{M}_z^{\alpha} = -\frac{S q b_A}{J_z} (m_z^{c_y a} c_{y a}^{\alpha})_0, 1/c^2;$$

$$c_3 = \bar{M}_z^{\delta_B} = \frac{S b_A}{J_z} (m_z^{\delta_B} q)_0, 1/c^2;$$

$$c_4 = \bar{Y}^{\alpha} = \frac{1}{m V_0} (\bar{Y}_a^{\alpha})_0, 1/c;$$

$$c_5 = -\dot{M}_z^{\dot{\alpha}} = -\frac{Sq b_A}{J_z} (m_z^{\dot{\alpha}})_0, 1/c^2;$$

$$c_6 = \frac{V_0}{57.3}, \frac{1}{c, \text{ град}};$$

$$c_9 = \bar{Y}^{\delta_B} = \frac{1}{mV_0} (\bar{Y}_a^{\delta_B})_0, \frac{1}{c}.$$

Differential equations of short-period motion of an aircraft in operator form have the form (6):

$$\begin{aligned} (s + c_1)\omega_z + (c_5s + c_2)\alpha &= -c_3\delta_B; \\ -\omega_z + (s + c_4)\alpha &= -c_9\delta_B; \\ -c_6v + c_6\alpha + s\Delta H &= 0; \\ \omega_z - s\vartheta &= 0. \end{aligned} \tag{6}$$

The linearized equations of the longitudinal motion of the aircraft in this case have the form (in the absence of wind) have the form (7):

$$\begin{cases} \dot{\theta} = c_4 \cdot \alpha + c_9 \cdot \delta_B; \\ \dot{\omega}_z = -c_1 \cdot \omega_z - c_2 \cdot \alpha - c_5 \cdot \dot{\alpha} - c_3 \cdot \delta_B; \\ \dot{\alpha} = \omega_z - c_4 \cdot \alpha - c_9 \cdot \delta_B; \\ \dot{v} = \omega_z; \\ \dot{H} = \frac{V}{57.3} \cdot \theta. \end{cases} \tag{7}$$

The transfer function for the angle of inclination of the trajectory has the form (8):

$$\dot{\theta} = c_4 \cdot \alpha. \tag{8}$$

Substitute (8) for equation (7):

$$\begin{cases} \dot{\alpha} = \omega_z - c_4 \cdot \alpha; \\ \omega_z = \dot{\alpha} + c_4 \cdot \alpha; \\ \dot{\omega}_z = \ddot{\alpha} + c_4 \cdot \dot{\alpha}. \end{cases} \tag{9}$$

Substitute expressions (9) into equation (7):

$$\begin{aligned} \ddot{\alpha} + c_4 \cdot \dot{\alpha} &= -c_1 \cdot (\dot{\alpha} + c_4 \cdot \alpha) - c_2 \cdot \alpha - c_5 \cdot \dot{\alpha} - c_3 \cdot \delta_B; \\ \ddot{\alpha} + \dot{\alpha}(c_4 + c_1 + c_5) + \alpha(c_1c_4 + c_2) &= -c_3 \cdot \delta_B; \end{aligned}$$

From expression (9) it will take the form:

$$\alpha(s) = \frac{-c_3}{s^2 + (c_4 + c_1 + c_5)s + c_1c_4 + c_2} \delta_B(s);$$

Substituting equation (7) we get:

$$n_y(s) = \frac{-c_3}{s^2 + (c_4 + c_1 + c_5)s + c_1c_4 + c_2} \frac{V \cdot c_4}{g \cdot 57.3} \delta_B(s);$$

Let's transform the expression (9) according to Laplace:

$$s \cdot \theta(s) = c_4 \cdot \alpha(s).$$

We will get the expression:

$$\theta(s) = \frac{-c_3 \cdot c_4}{s[s^2 + (c_4 + c_1 + c_5)s + c_1c_4 + c_2]} \delta_B(s);$$

Let's express from expression (7) and transform it according to Laplace:

$$\omega_z(s) = s \cdot \alpha(s) + s \cdot \theta(s);$$

$$s \cdot \vartheta(s) = \omega_z(s);$$

$$s \cdot H(s) = \frac{V}{57.3} \cdot \theta(s);$$

We will get:

$$\omega_z(s) = \frac{-c_3(s + c_4)}{[s^2 + (c_4 + c_1 + c_5)s + c_1c_4 + c_2]} \delta_B(s);$$

$$\vartheta(s) = \frac{-c_3(s + c_4)}{s[s^2 + (c_4 + c_1 + c_5)s + c_1c_4 + c_2]} \delta_B(s);$$

$$H(s) = \frac{-c_3c_4V}{s^2[s^2 + (c_4 + c_1 + c_5)s + c_1c_4 + c_2]57.3} \delta_B(s).$$

The functional diagram of the automatic control system of the aircraft is shown in Figure 1.

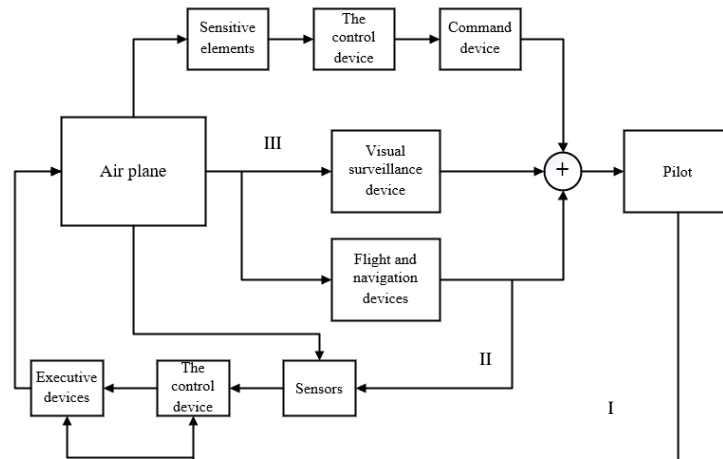

Figure 1 Functional diagram of the aircraft automatic control system

Changing the pitch angle affects the longitudinal movement of the aircraft. The pitch control system ensures maintenance of a given trajectory in the vertical plane. The system provides the ability to manually or automatically change the pitch angle, carried out according to signals from the trajectory control system.

The functional diagram of the aircraft's automatic pitch angle control system is shown in Figure 2.

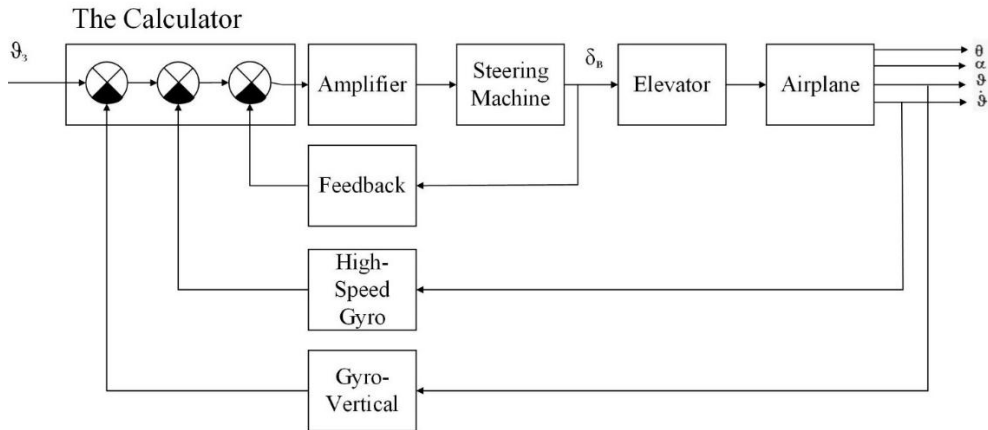

Figure 2 Functional diagram of the aircraft's automatic pitch angle control system

Suppose that the feedback in the autopilot is rigid, and there is no high-speed gyroscope signal, then the control law can be represented as:

$$\delta_B = K_\vartheta (\vartheta - \vartheta_{зад}).$$

To improve the control process, it is necessary to increase the damping moment by introducing a signal proportional to the angular velocity of the pitch into the control law:

$$\delta_B = K_\vartheta (\vartheta - \vartheta_{зад}) + K_\dot{\vartheta} s\vartheta.$$

The block diagram of the automatic control system is shown in Figure 3.

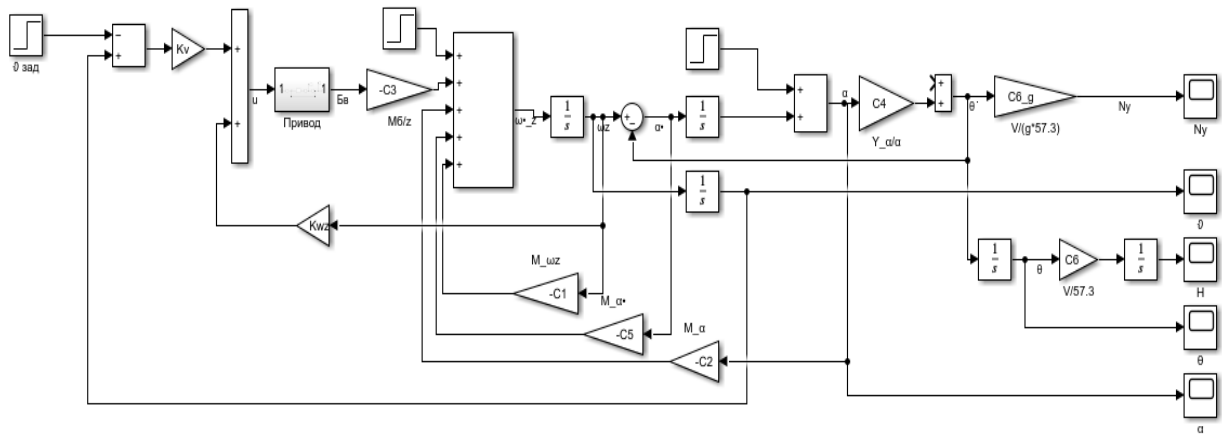

Figure 3 Block diagram of the aircraft's automatic pitch angle control system

III. THE METHOD OF STANDARD COEFFICIENTS

In this method, it is assumed that the structure of the CAY is given, i.e. the type of transfer function of a closed system is known, and the determination of the values of the coefficients of the transfer function provides a given transition time, stability and optimal overshoot.

The transfer function of a closed system in the form should be reduced to the Vyshnegradsky form.

$$W(p) = \frac{B(p)}{A(p)} = \frac{b_m p^m + \dots + b_1 p + b_0}{a_n p^n + \dots + a_1 p + a_0}$$

Dividing the numerator and denominator by a_n , we get:

$$W(p) = \frac{\frac{b_m}{a_n} p^m + \dots + \frac{b_1}{a_n} p + \frac{b_0}{a_n}}{p^n + \dots + \frac{a_1}{a_n} p + \frac{a_0}{a_n}}$$

Let's introduce the notation:

$$\frac{a_0}{a_n} = \Omega_0^n, \tau = \Omega_0 t, p = \Omega_0 p \tau, \frac{a_1}{a_n} = A_1 \Omega_0^{n-1}, \frac{a_2}{a_n} = A_2 \Omega_0^{n-2}, \frac{a_3}{a_n} = A_3 \Omega_0^{n-3} \dots$$

A_1, A_2, \dots - the parameters of the Vyshnegradsky.

We will write the transfer function in the form

$$W(p_\tau) = \frac{B_m p_\tau^m + \dots + B_1 p_\tau + B_0}{p_\tau^n + \dots + A_2 p_\tau^2 + A_1 p_\tau + 1},$$

$$B_m = \frac{b_m}{a_n} \Omega_0^{m-n}, B_1 = \frac{b_1}{a_n} \Omega_0, B_0 = \frac{b_0}{a_n}$$

For all multiple roots, the coefficients of the characteristic equation in the Vyshnegradsky form are the coefficients of the Newton binomial

$$p^n + A_{n-1} p^{n-1} + \dots + A_1 p + 1 = (p+1)^n$$

Order	Coefficients of the equation (binomial coefficients)										
1						1		1			
2				1		2		1			
3			1		3		3		1		
4		1		4		6		4		1	
5		1		5		10		10		5	
6	1		6		15		20		15		6
											1

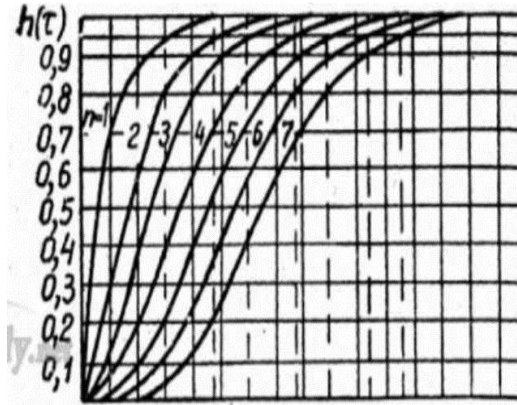

Fig. 4. Transition functions for a normalized transfer function with multiple roots (the order of the equation $u = 1.2. 3.4. 5. 6. 7$)

The values of the coefficients A_1, \dots, A_{n-1} can be recommended for ACS with transfer functions that do not have zeros.

The zeros of the transfer function can significantly affect the type of transition process (the zeros of the transfer function are the roots of the numerator).

$$B(p) = b_m p^m + \dots + b_1 p + p_0$$

The zeros of the transfer function for all positive b_0, b_1, \dots, b_m contribute to overshoot.

The transition function $h(t)$ is formed as the sum of the transition function $h_0(t)$ and t of its derivatives, where $h_0(t)$ is the transition function in the absence of zeros when $B(p) = b_0$.

IV. RESULTS

4.1. Synthesis of a system for stabilization of a given pitch angle with a static overload internal loop for stabilization of a normal overload n_y

The law of autopilot control: $\delta_B = K_{n_y} n_y + K_{\omega_z} \omega_z + K_{n_y} K_{\vartheta} (\vartheta - \vartheta_{зад})$.

Using the method of standard coefficients, we get:
$$\begin{cases} K_{n_y}^{\vartheta} = -0,18; \\ K_{n_y} = -0,9; \\ K_{\omega_z} = 0,1. \end{cases}$$

A block diagram when $W_{np} = \frac{\omega_{np}^2}{s^2 + 2\xi_{np}\omega_{np}s + \omega_{np}^2}$ with the coefficients found is shown in Figure 5.

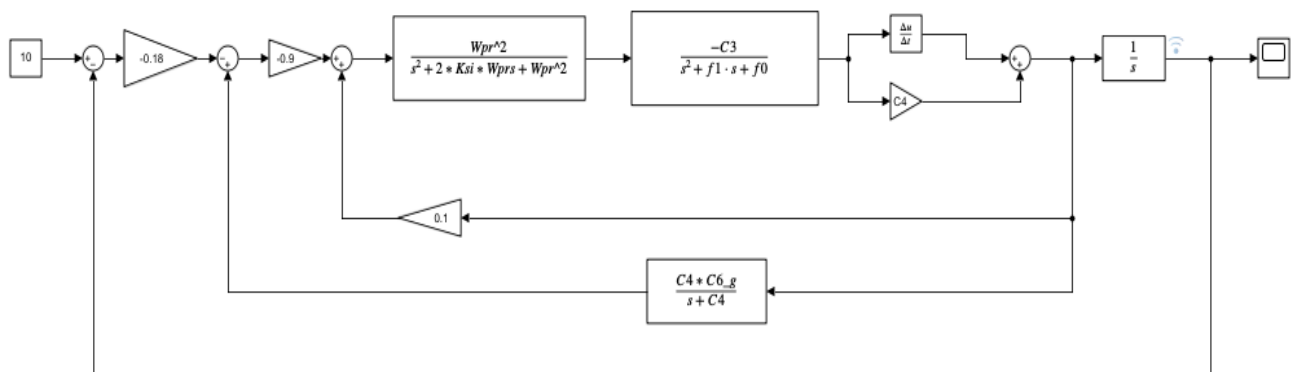

Figure 5 Block diagram of a system with calculated coefficients

Calculation of the coefficients of a system with specified quality indicators based on the method of standard coefficients with multiple roots, obtaining the transition time is 5.8 seconds.

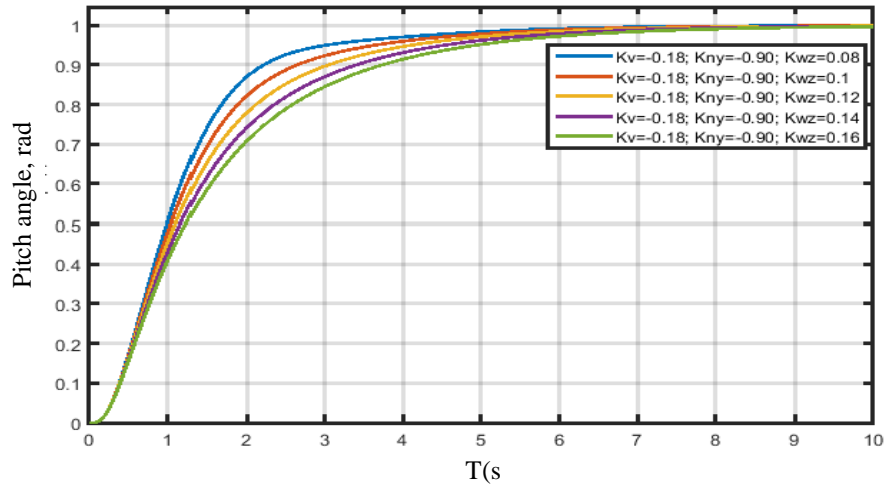

Figure 6 A graph of the processes of working out a given pitch angle ($\vartheta_{зад}=1$ degree) pitch stabilization systems with static internal stabilization circuit of normal overload n_y

The graph of the processes of stabilization of the pitch angle at a constant perturbing moment $M_{B03M}=1$ of the pitch stabilization system with a static overload internal circuit is shown in Figure 7

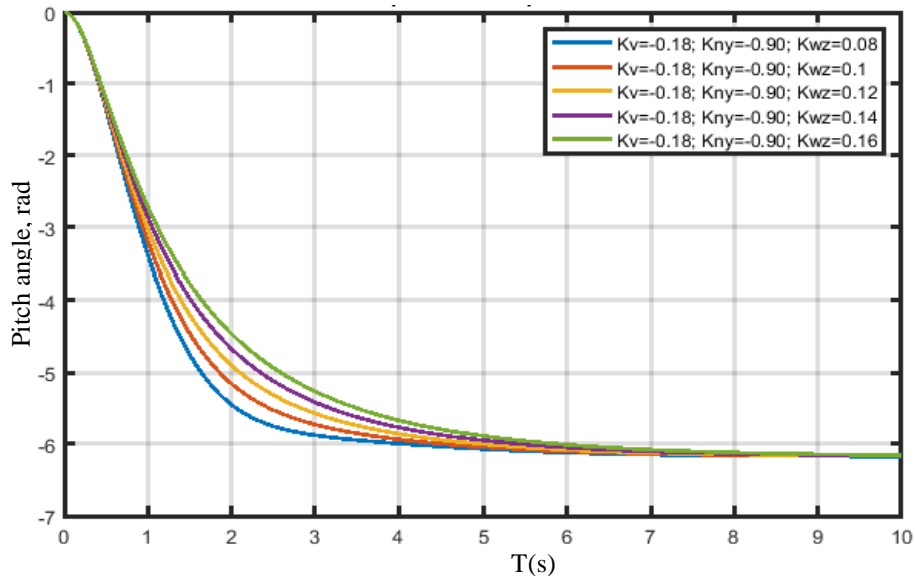

Figure 7 shows a graph of the processes of stabilization of the pitch angle at a constant perturbing moment $M_{B03M} = 1$ of the pitch stabilization system with a static overload internal circuit

A graph of the processes of stabilization of the pitch angle at the entrance to the vertical air flow ($\alpha_w = 1$ degree) of the pitch stabilization system with a static overload internal circuit is shown in Figure 8.

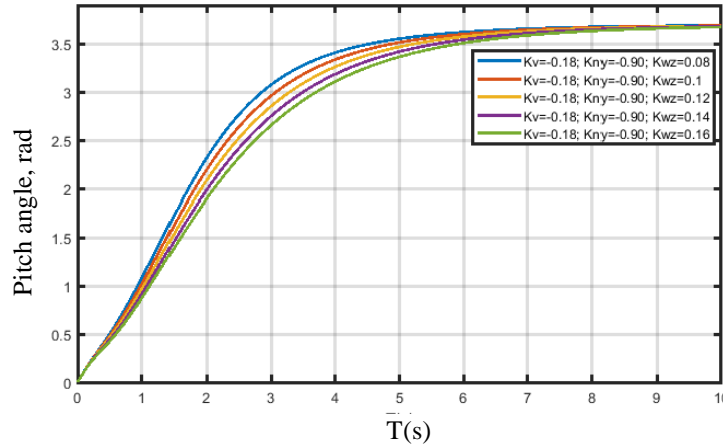

Figure 8 shows a graph of the processes of stabilization of the pitch angle at the entrance to the vertical air flow $\alpha_w=1$ degree of the pitch stabilization system with a static overload internal circuit

4.2. Synthesis of a system for stabilization of a given pitch angle with an astatic overload internal loop for stabilization of a normal overload n_y

The law of autopilot control:

$$\delta_B = K_{iny} \times K_{n_y}^\vartheta \int (\vartheta_{зад} - \vartheta) dt + K_{iny} \int n_y dt + K_{n_y} n_y + K_{\omega_z} \omega_z.$$

Using the method of standard coefficients, we get:

$$\begin{cases} K_{n_y}^\vartheta = 0,32; \\ K_{iny} = 3,5; \\ K_{n_y} = 1,7; \\ K_{\omega_z} = 0,45. \end{cases}$$

A block diagram when $W_{np} = \frac{\omega_{np}^2}{s^2 + 2\xi_{np}\omega_{np}s + \omega_{np}^2}$ with the coefficients shown is shown in Figure 9.

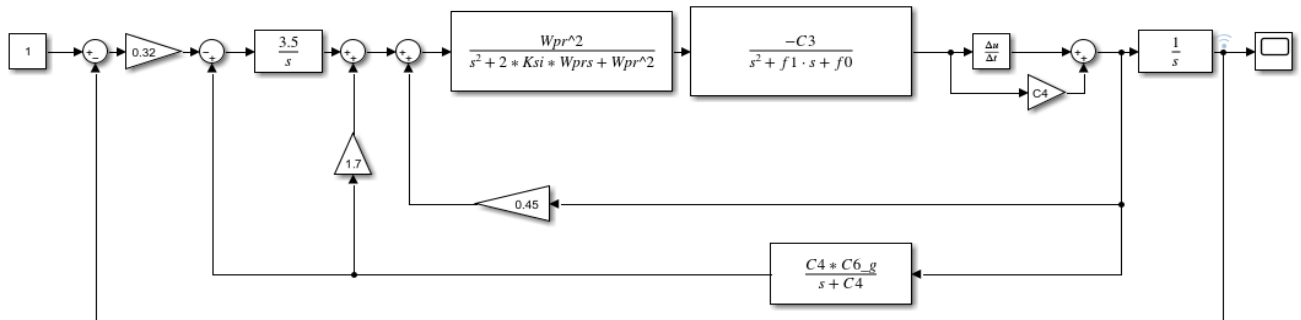

Figure 9 Structural diagram with the found coefficients

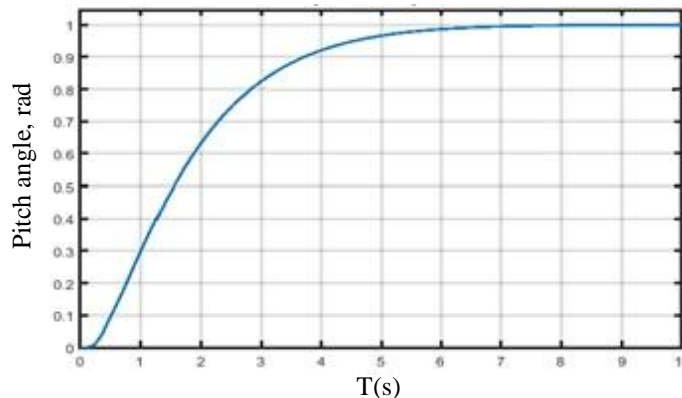

Figure 10 The transition process of the system with the found coefficients

A graph of the processes of working out a given pitch angle ($\vartheta_{зад}=1$ degree) of a pitch stabilization system with an astatic internal contour for stabilizing normal overload is shown in Figure 11.

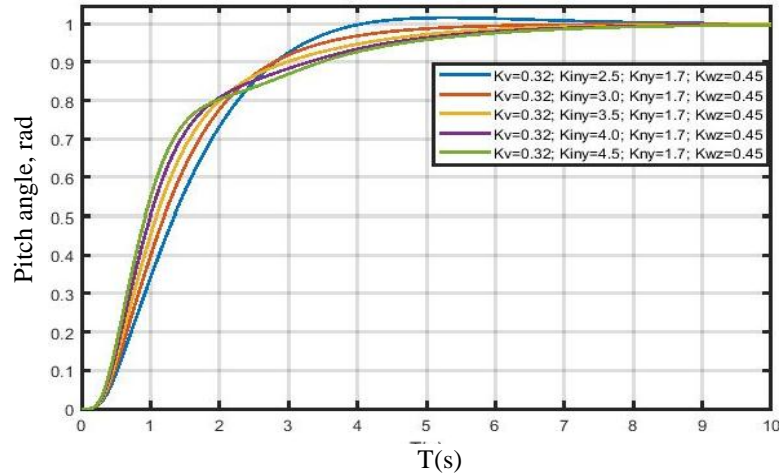

Figure 11 A graph of the processes of working out a given pitch angle. ($\vartheta_{3a1}=1$ degree) pitch stabilization systems with an astatic internal loop for normal overload stabilization

A graph of the processes of stabilization of the pitch angle at a constant disturbing pitch moment ($M_{B03M} = 1$) with an astatic internal stabilization circuit of normal overload n_y is shown in Figure 12.

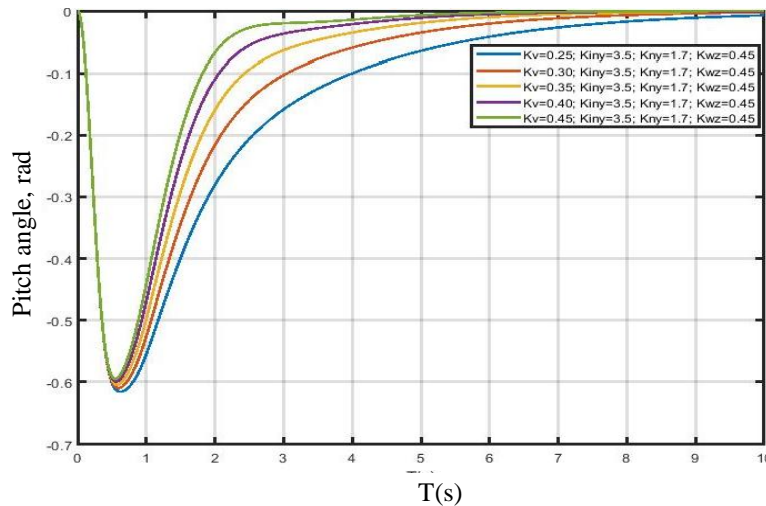

Figure 12 Graph of the processes of stabilization of the pitch angle at a constant disturbing pitch moment ($M_{ZB03M} = 1$) with an astatic internal contour of stabilization of normal overload

The transients of the pitch angle stabilization system at the entrance to the vertical air flow $\alpha_w=1$ degree of a static pitch stabilization system with a static overload internal circuit are shown in Figure 13.

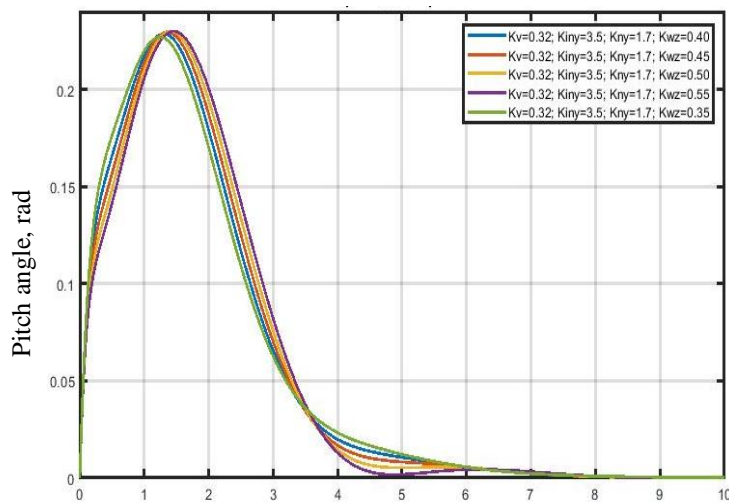

Figure 13 Graph of the processes of stabilization of the pitch angle at the entrance to the vertical air flow $\alpha_w=1$ degree of the pitch stabilization system with a static overload internal circuit

V. CONCLUSION

In the study of the vertical channel automatic control system of aircraft using the standard coefficient method there are the following results:

- In the static scheme of the pitch angle control system with a static internal contour for stabilizing normal overload, with a decrease in the coefficients $K_{\omega_z}, K_{n_y}^0, K_{n_y}$, the operating speeds increase, the transition time is 6 seconds, decreased by 10%, i.e. the transition time decreases.

- With the static scheme of the pitch angle control system with an astatic internal stabilization loop of the normal overload n_y , the transient process is quickly established, but there was no static error. With an increase in the coefficients K_{n_y} and $K_{n_y}^0$, the speed of the calculation system, the control time $t_p = 5-8$ s decreased by 5%, overshoot $\sigma = 0\%$. When the coefficients K_{ω_z} and $K_{i_{n_y}}$ decrease, the oscillation of the system decreases, i.e. the system is more stable.

The standard coefficient method helps to select the coefficients with the appropriate value in the permissible range, so that the system meets the transition process, reducing the transition time, the correction...and can be applied in many other higher level systems.

REFERENCES

- [1]. Efremov A.V., Zakharchenko V.F., Ovcharenko V.N., Sukhanov V.L. [2017] "Dynamics and control of aircraft motion". Mechanical Engineering-Flight, p 775.
- [2]. Berezuev A.V., Eliseev V.D., Kuznetsov A.G., Mulin P.V. [2017] "Dynamics of longitudinal motion of aircraft", MAI, p 85.
- [3]. Rybnikov S.I, Nguyen Thanh Son. [2017] "Analytical design of a damping system for bending aeroelastic vibrations of an airplane wing", MAI, Vol 95: p 24.
- [4]. Mikhalev I.A., Okoemov B.N., Chikulaev M.S. [1987] "Automatic aircraft control systems", Mechanical engineering, p 240.
- [5]. V.G. Vorobyov, S.V. Kuznetsov. [1995] "Automatic flight control of aircraft".
- [6]. V.V. Vorobyov, A.M., Kiselyov, V.V. Polyakov. [2008] "The dynamics of an airplane flight", p 197.
- [7]. Kuznetsov A.G., Berezuev A.V. [2019] "Automatic control systems for longitudinal short-period aircraft movement", MAI, p 144.
- [8]. Abidarova A.A. [2020] "Automated system in aviation: safety and concept", Proceedings of Tula State University. Technical sciences, Vol 4: p 88-92.
- [9]. Bezuevsky A.V. [2019] "Features of the characteristics of static and dynamic aeroelasticity of aircraft with a large elongation wing", p 151.
- [10]. Letov A.M. [1969] "Flight dynamics and control", Moscow: Technology, p 360.
- [11]. G.S. Buchgens. [2011] "Dynamics fields", Moscow: Mechanical engineering, p 776.
- [12]. Timakov S.N., Zhimov A.V. [2014] "Algorithms of active damping of elastic vibrations of the International Space Station structure", Bulletin of the Bauman Moscow State Technical University. Instrumentation, Vol 3(96), pp 37.